

ML01 SERIES

Fail-Safe / Power to lock

ELECTRO MAGNETIC LOCK_1200P

(Surface Mounted)



- Magnet (ML01) : 266L*73W*40D mm
- Armature Plate : 185L*61W*16T mm

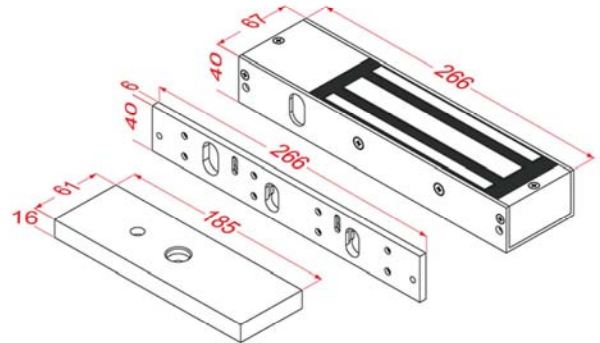

ORDERING INFORMATION

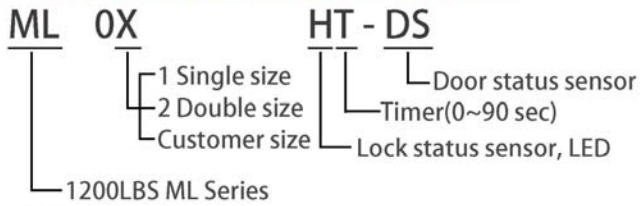

EXAMPLE :

- ML01H : Maglock 1200P. W/Lock status sensor
- ML02H : Maglock 1200P. Double Size . W/Lock status sensor

SPECIFICATION

- Voltage : 12V / 24VDC (Selectable)
- Current Draw : 500mA/12V , 250mA /24V
- Holding Force : about 1200 LBS
- Built-in voltage spike suppressor
- Special Finish : Zinc (on the magnet & armature plate)
- With Bi-color LED
- Anodized aluminum housing
- Adjustable mounting plate for appropriate and easy installation
- the length can be added according to customer's request

FEATURES

- Horizontal or vertical installation
- Special mounting plate for fast , effort-saving, and simple installation



- Anti-dismounting and Anti-falling function



- Magnet (ML02) : 532L*73W*40D mm

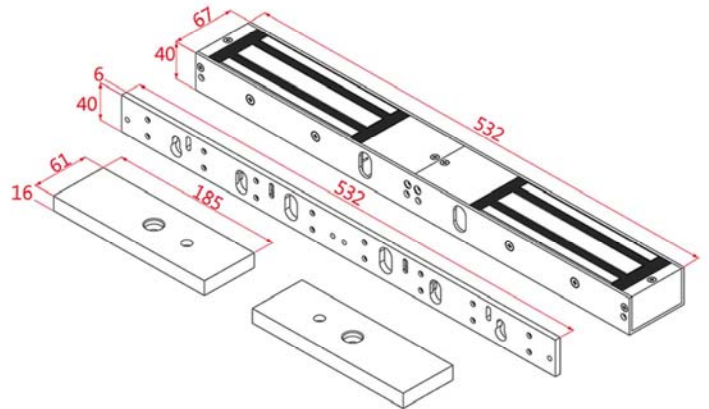

BRACKETS INSTALLATION



B1003 - L Bracket



B1002A - L&Z Bracket

B1001 - Adjustable L Bracket



U-185 Bracket



Double size



B1004 / B1005



B0001A - Armature Plate Housing

SIGNALING

