

# GL1200 SERIES

Fail-Safe / Power to lock

# ELECTRO MAGNETIC LOCK\_1200P

(Side Mounted) (water-proof)



- Magnet (GL1200) : 203L\*63.5W\*41Dmm
- Armature Plate : 185L\*61W\*16T mm

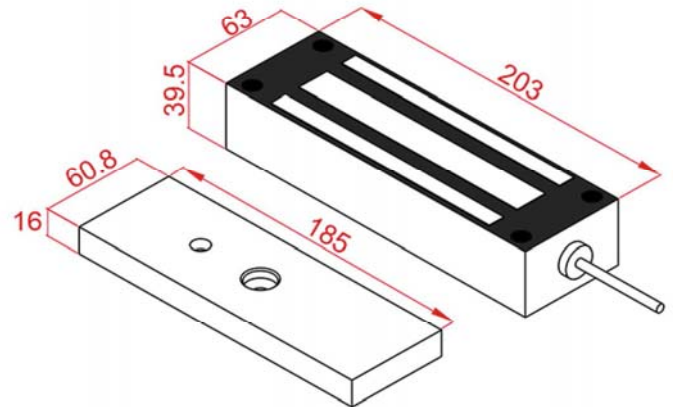

## ▼ ORDERING INFORMATION



EXAMPLE :

- GL1200 : Gatelock 1200P Unmonitored , Face mounted (203Lmm)
- GL1200S : Gatelock 1200P Unmonitored, Side mounted (220Lmm)
- GL1200R : Gatelock 1200P W/Lock status sensor, Face mounted (203Lmm)
- GL1200SR : Gatelock 1200P W/Lock status sensor, Side mounted(220Lmm)

- Magnet (GL1200S) : 220L\*63.5W\*41Dmm

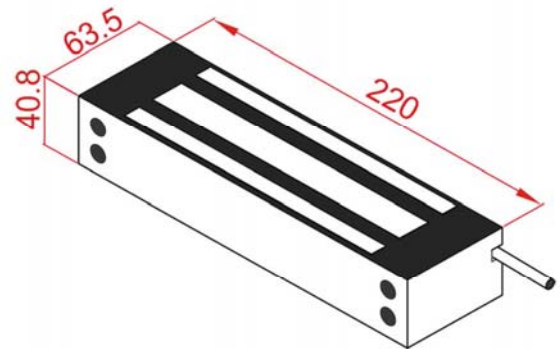

## ▼ SPECIFICATION

- Stainless steel housing,
- Built-in voltage spike suppressor
- Voltage : 12V/24VDC (Selectable)
- Current Draw : 500mA/12V , 250mA /24V
- Holding Force : about 1200LBS
- Special Finish : Zinc (on the magnet & armature plate)

## ▼ FEATURES

- For out door use (water-proof) - all inner components are well sealed and be protected from environmental damages.
- Side power cable for various installation environments ( GL1200S only)
- Horizontal or vertical installation

## ▼ BRACKETS INSTALLATION



B1003-L Bracket



B1200 - L&Z Bracket



U-185 Bracket



B0001A - Armature Plate Housing



B1004 / B1005

SIGNALING

